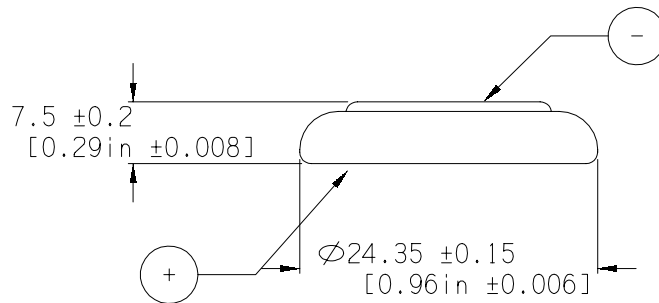

DATE: 03/22/01

BATTERY SPECIFICATION

P/N CR2477

**TYPICAL SPECIFICATIONS**

ELECTROCHEMICAL SYSTEM: LITHIUM MANGANESE DIOXIDE

NOMINAL VOLTAGE: 3.0

MAXIMUM OFF-LOAD VOLTAGE: 3.7

RATED CAPACITY: 1000mAh TO 2.0V AT 20°C (68°F)

AVERAGE WEIGHT: 0.352 oz (10.0 g)

OPERATING TEMP. RANGE: -20°C TO 60°C (-4°F TO 140°F)

ANSI DESIGNATION:

TYPICAL USE	LOAD (OHMS)	DAILY PERIOD	END POINT V	MINIMUM AVERAGE DURATION
RATING	6.8K	24 hr	2.0	2507 hr

TYPICAL MPD HOLDER NO. BH1000G

SEE MANUFACTURER'S SPECIFICATION SHEET FOR FURTHER INFORMATION.

AWI	DURACELL	EVEREADY	IEC	KODAK	MAXELL	NEDA	PANASONIC	RENATA	SONY	TOSHIBA	VARTA	OTHER
							CR2477	CR2477	CR2477			